

JOY HC AO2DO | HC 3AO | RS485 Modbus

Room Regulator (from Version 2.6.x)

thermokon[®]
HOME OF SENSOR TECHNOLOGY

Datasheet

Subject to technical alteration
Issue date: 01.09.2022 • A124

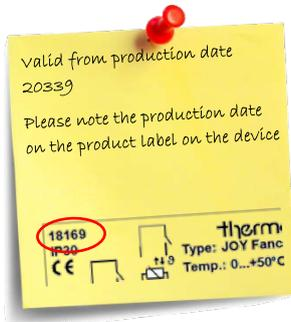

» APPLICATION

JOY HC AO2DO (85..260 V ~)

Room thermostat in an appealing design for heating/cooling (230 V) and controlling a 6-way valve. Used for individual control of temperature in commercial and residential buildings. The device combines a modern design with a 2,5" touch surface, which enables the single room controller to be used intuitively. 3 time channels with 4 periods of time can be configured via the menu. This device is suitable for a flush mount box.

JOY HC 3AO (24 V ~/=)

Modern design, flush mounting room thermostat. Used for individual control of temperature in commercial, industrial and residential buildings. It is tailored for two-pipe and four-pipe units with two-wire electric valves and controlling a 6-way valve. The device combines a modern design with a 2,5" LCD and a touch-sensitive surface, 3 time program options each with 4 time periods options.

» SECURITY ADVICE – CAUTION



The installation and assembly of electrical equipment should only be performed by authorized personnel. The product should only be used for the intended application. Unauthorised modifications are prohibited! The product must not be used in relation with any equipment that in case of a failure may threaten, directly or indirectly, human health or life or result in danger to human beings, animals or assets. Ensure all power is disconnected before installing. Do not connect to live/operating equipment.



CAUTION! Risk of electric shock due to live components within the enclosure, especially devices with mains voltage supply (usually between 90..265 V).

Please comply with:

- Local laws, health & safety regulations, technical standards and regulations
- Condition of the device at the time of installation, to ensure safe installation
- This data sheet and installation manual

» PRODUCT TESTING AND CERTIFICATION



Declaration of conformity

The declaration of conformity of the products can be found on our website <https://www.thermokon.de/>

» NOTES ON DISPOSAL



As a component of a large-scale fixed installation, Thermokon products are intended to be used permanently as part of a building or a structure at a pre-defined and dedicated location, hence the Waste Electrical and Electronic Act (WEEE) is not applicable. However, most of the products may contain valuable materials that should be recycled and not disposed of as domestic waste. Please note the relevant regulations for local disposal.

» MOUNTING ADVISE ROOM SENSORS

The Accuracy of the room sensors are influenced by the technical specifications as well as the positioning and the installation type.

During Assembly:

- Seal mounting box (if present).
- Installation type, air draught, heat source, radiation heat or direct sunlight can affect the measurement.
- Bulding material specific properties of the installation place (*brick-, concrete-, partition wall, cavity wall, ...*) can affect the measurement. (*e.g.: Concrete accepts room temperature variation slower than cavity walls*)

Assembly not recommendet in...

- Air draught (e.g.: close to windows / doors / fans ...)
- Near heating sources,
- Direct sunlight
- Niches / between furniture / ...

» DIAGNOSTICS MENU

To access the diagnostics menu, select the header in the startscreen of the parameter menu, and press the ENTER key. Here you will find various information, such as device type, software version, state of the inputs and outputs and controller state (current manipulated variable).

» MOUNTING ADVICES

Plasterboard boxes shall be covered by wall paper or paint to avoid that the plasterboard box's front rim will be partially visible underneath JOY. Maybe consider using white plasterboard boxes (i.e. Kaiser 9063-77).

» APPLICATION NOTICE

Boot Loader

A bootloader integrated in the device, makes it possible to install a new application (update, upgrade) using a MicroSD card. To insert the SD card, the upper part must be removed. If the boot loader is activated, the ring illumination blinks in a 1s cycle, while display is not triggered! After recognition of a MicroSD card with a valid application the update process is started. Now, ring illumination blinks fast in a 300ms cycle. After a successful update process (Duration approx. 20-30 seconds!), the new application is started automatically. Afterwards, SD card have to be removed!

MicroSD-Card

MicroSD cards can be used to upload a new application or a new device configuration. Only MicroSD cards formatted in the FAT file system can be used! NTFS and exFAT file systems are not supported.

Software

A detailed description of the parameter and the configuration software can be downloaded from our website.

The parameters for the display, set point and the controller can only be changed via the configuration software.

» CONFIGURATION VIA UCONFIG | MICROSD-CARD OR MODBUS



Configuration

uConfig | Windows 10 is required to use the uConfig configuration software

The JOY room thermostat can be parameterised using the uConfig configuration software. An SD card is used to transfer the created configuration file to the device. For BUS devices, a live configuration can also be performed via the BUS interface.

software:

The installer for the configuration software can be found in the Download-Section on our website. The installer retrieves all necessary files and plug-ins from our web server. In this version an update function is integrated in the software.

Download-Section

» CONNECTION PLAN

JOY HC AO2DO (85..260 V ~)

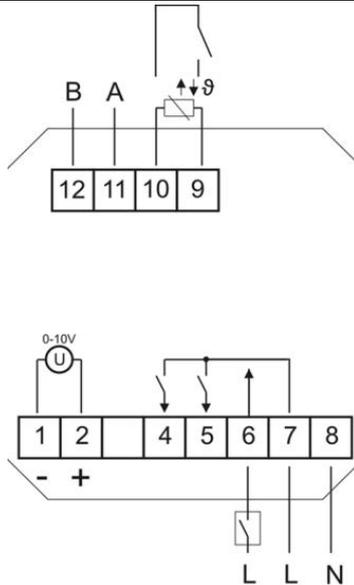

1 GND (6-way valve)
2 0..10 V (6-way valve)
4 Cooling
5 Heating
6 Digital Input 2 (230V)
7 L
8 N
9 Digital Input 1 (or NTC10K)
10 GND DI 1
11 Modbus A
12 Modbus B

JOY HC 3AO (24 V ~/=)

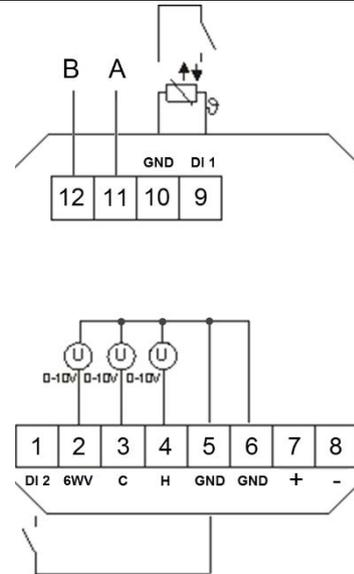

1 Digital Input 2
2 6-way valve (0..10 V)
3 Cooling (0..10 V)
4 Heating (0..10 V)
5 GND DI2
6 GND
7 24 V = (±10%) or 24 V ~ (±10%)
8 GND
9 Digital Input 1 (or NTC10K)
10 GND DI 1
11 Modbus A
12 Modbus B

Note: Parallel connection of the potential-loaded inputs is not permitted!

If the operating mode (change-over DI) of several devices is to be switched together by one contact, the potential-free 230V input must be used (DI2, only possible with the 230V version). It must be ensured that the same phase is used for jointly switched devices.

» TECHNICAL DATA

» JOY HC AO2DO | HC 3AO

Measuring values	temperature, humidity (<i>optional</i>)	
Network technology	RS485 Modbus RTU, Fail-safe Biasing required	
Measuring range temp	0..+50 °C	
Accuracy temperature	±1 K (typ. at 21 °C)	
Measuring range humidity (<i>optional</i>)	0..100% rH non-condensing	
Accuracy humidity (<i>optional</i>)	±2% between 10..90% rH (typ. at 21 °C)	
Control functions	setpoint adjustment +0..+50 °C	
Display	LCD 60x44 mm, 240x160 px, white backlighting	
Functions	integrated PI- and 2-point-/ 3-point-controllers, 2nd control loop: 2-point controller	
Enclosure	PC, glass, optional black or white	
Protection	IP30 according to EN 60529	
Connection electrical	Terminal 1..8 terminal block max. 1,5 mm ²	Terminal 9..12 terminal block max. 1.0 mm ²
Ambient condition	0..+50 °C, max. 85% rH non-condensing	
Weight	195 g	
Mounting	flush mounted with standard EU box (Ø=60 mm)	

» JOY HC AO2DO

Output voltage	0..10 V =, max. load 5 mA (for 6-way valves)	
Output switch contact	2x normally open contacts (heating/cooling), 240 V max. load 500 mA	
Power supply	85..260 V ~	
Power consumption	max. 3 VA (260 V ~)	
Inputs	DI1 input for NTC 10 K or floating contact	DI2 digital input for non-floating contact (230 V ~)

» JOY HC 3AO

Output voltage	3x 0..10 V, max. load 5 mA, 6-way valve control, heating & cooling)	
Power supply*	24 V = (±10%) or 24 V ~ (±10%) SELV	
Power consumption	max. 2,5 W (24 V =)	
Inputs	DI 1 1 input for NTC10K or floating contact	DI 2 input for floating contact

*Power supply

When several BUS devices are supplied by one 24 V AC voltage supply, it is to be ensured that all "positive" operating voltage input terminals (+) of the field devices are connected with each other and all "negative" operating voltage input terminals (-) (=reference potential) are connected together (in-phase connection of field devices).

In case of reversed polarity at one field device, a supply voltage short-circuit would be caused by that device. The consequential short-circuit current flowing through this field may cause damage to it.

Therefore, pay attention to correct wiring.

» **FUNCTION DESCRIPTION – CONTROLLER**

JOY HC AO2DO (85..260 V ~)	JOY HC 3AO (24 V ~/=)
PI controller (PWM) & 2-point/3-point controller (configurable)	PI controller (0..10 V)

6WV (PI-controller 0..10 V) (all types)

The manipulated variable is output as a proportional control signal at the output for the 6-way valve. The type of valve used is set via the configuration software. You can choose from 2..10 V / 2..10 V INV (Belimo), 0..10 V DN15 / DN15 INV, DN20 / DN20 INV (Sauter). There is also the possibility of a freely parameterizable 6-way valve (generic 6WV).

Heating/ cooling with 2-point-/ 3-point-controller (only HC AO2DO)

In the case of temperature control, the 2-point controller only knows the switching states heating ON and heating OFF. The 3-point controller also knows the switching state of cooling. Two - and three-point controller work with a hysteresis.

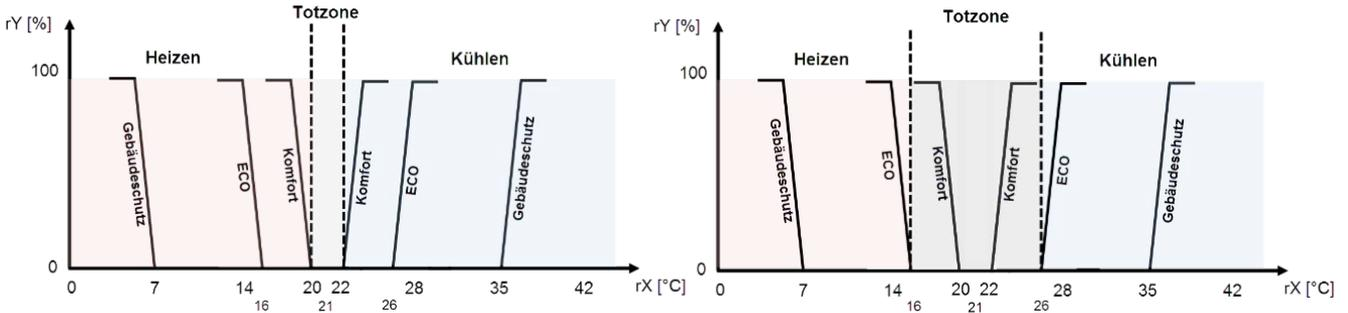

Heating/ cooling with PI-controller (PWM) (only HC AO2DO)

The time response of the PI control loop depends on the control parameters xp for the proportional area and tn for the reset time of the integral range. In case of an error, the P portion immediately changes the position value proportionally to the error variable, while the integral portion takes effect after a certain time.

The resulting actuating variable is output as a pulse-width-modulated signal directly to the outputs.

Heating/ cooling with PI-controller (0..10 V) (only HC 3AO)

The time response of the PI control loop depends on the control parameters xp for the proportional area and tn for the reset time of the integral range. In case of an error, the P portion immediately changes the position value proportionally to the error variable, while the integral portion takes effect after a certain time.

The resulting manipulated variable is output as an analogue 0..10 V signal directly to the outputs.

» FUNCTION DESCRIPTION - BUTTONS

On the touch-surface are the keys for setpoint adjustment. While pressing of these buttons, the white LED of the Power-button lights up for visual feedback.

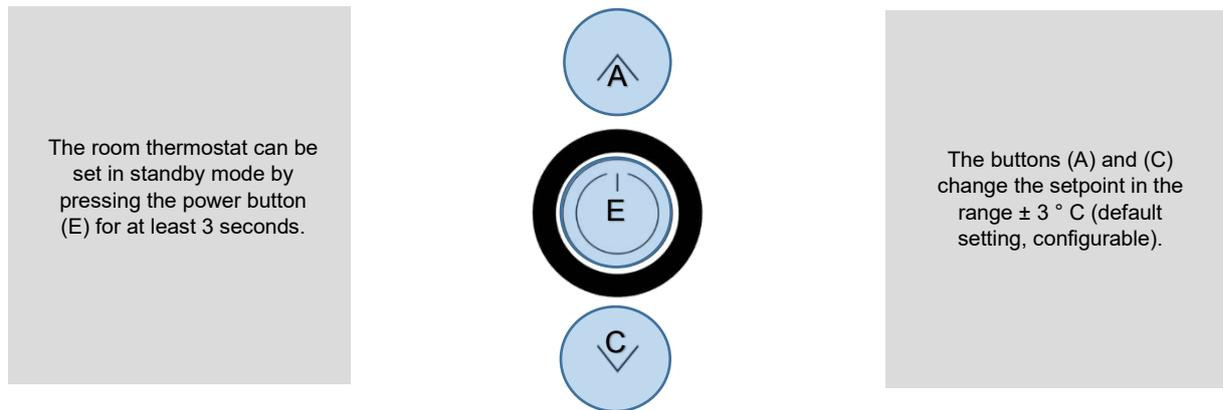

The Power button (E) can be used to switch the room thermostat to standby mode (not possible if the Keycard switch function is used!) If the key is used as a presence key at the same time, the key must be pressed for at least 3s, in all other cases a short press is sufficient. In standby mode the display and all outputs are switched off (controller deactivated). The frost and heat protection monitoring remains active. **Modbus registers can still be read (e.g. room temperature).**

Main screen/ Value display

The Display shows the measured value of the internal sensor. The value of an external sensor will be shown if connected and configured accordingly. The room thermostat controls in this case according to the external sensor.

Header →	13:41  06.08.25	13:41  06.08.25
Value display → (Humidity optional)	23.3 °C	56.6 %rH 23.3 °C
Footer →	 	 

Header

In the header line, the time, weekday and date are displayed. In addition, the ECO info symbol (sheet) is displayed here when the ECO mode is switched on. It is possible to show an alarm symbol (exclamation mark) in the display. This symbol is located at the same position as the ECO symbol. Since the alarm symbol has a higher priority, it overwrites the ECO symbol.

Footer - Symbols

Depending upon the heating or cooling mode, occupancy or window contact status, the corresponding symbols will be shown in the footer. The symbol "active timechannel" will be shown only if active.

Occupancy		
Window contact/dewpoint		
Heating/Cooling		
Active timechannel		

» CONFIGURATION VIA THE DISPLAY MENU

Buttons

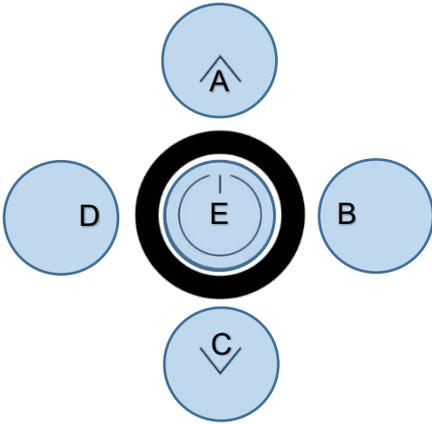

The configuration menu is called up by simultaneously pressing the buttons “up” (A), “left” (D) and “right” (B) for at least 3 seconds.

Menu navigation on the touch-surface is performed by pressing the buttons “up” (A), “down” (C), “left” (D), “right” (B) or the power button. Choose the desired parameter and press “right” (B) to open up the submenu. If no entry is made for 8 minutes, the parameter menu is left automatically. To exit the menu select the header line and press “left” (D)

Menu	
Timechannels	▶
Time/Date	▶
Sensor settings	▶
Common settings	▶

» MENU → TIME CHANNELS

In the Time Channels menu, setpoint and timer can be set. Up to 3 time channels with 4 time periods each can be parameterized. The time channels are prioritised. Channel 3 has the highest priority. After selecting the line of the time channel to be edited, the next submenu is called up with the "Right" key. It is possible to set any time period within one week in the first two lines with the "Left" (-) / "Right" (+) keys. In addition, the ECO mode is available in the menu sections. In ECO mode, the dead zone between heating and cooling is automatically set to the ECO dead zone configured in the "General Settings" menu (default: 10 K).

Timechannels		Timechannels/Timer1		Periods/Period1	
Timechannel 1	Mo - Fr	from day	<-/+> Mo	Start	<-/+> 06:00h
Timechannel 2		to day	<-/+> Fr	Temp	<-/+> 22.0°
Timechannel 3		1: 06:00h	- A - 22.0° ✓▶	ECO-Mode	✓
		2: 08:30h	- 1 - 20.0° ✓▶		
		3: 16:00h	- A - 22.0° ✓▶		
		4: 22:30h	- 0 - 22.0°ECO ✓▶		

» MENU → TIME/DATE

Time, Date and display format can be configured in the menu settings. The room thermostat is equipped with a real-time clock so that it automatically adjusts for daylight-saving time. This function can be disabled in the datetime settings.

Menu		Datetime setting/Time		Datetime setting/Date	
Timechannels	▶	Hour	<-/+> 13	Day	<-/+> 12
Time/Date	▶	Minute	<-/+> 07	Month	<-/+> 08
Sensor settings	▶	12h/24h	<-/+> 24h	Year	<-/+> 15
Common settings	▶	Daylight saving	<-/+> CET	Presentation	<-/+> T.M.J
		Date	▶		

» MENU → SENSOR SETTINGS

Offset correction for internal and external sensor value. The temperature display can also be changed from °C to °F.

Menu	Sensor settings
Timechannels	Offset int. ◀-/▶ 0.6 K
Time/Date	Value int. 22.1°C
Sensor settings	Offset ext. ◀-/▶ 0.2 K
Common settings	Value ext. 22.1°C
	Unit ◀-/▶ Celsius

» MENU → COMMON SETTINGS

The common settings includes the brightness of the background lighting and the LED. Valve protection prevents the valves becoming ceased when they are switched off for long periods. If the valve protection function is activated, a valve-check is carried out every Friday at 11:00 am for the heating valve and 11:15 am for the cooling valve. The corresponding valve is triggered for 5 minutes, if not activated during the last 96 hours. The dead band can be adjusted (default 10.0 K, see timechannels).

Menu	Settings/Common	Settings/Common	Settings/Language
Timechannels	Brightness LCD ◀-/▶ 100%	Valve protect ◀-/▶ ON	Deutsch ✓
Time/Date	Brightness LED ◀-/▶ 100%	ECO deadband ◀-/▶ 10.0K	English
Sensor settings			
Common settings	Common ▶	Language ▶	Factory setting ▶

Factory settings

By selecting "Factory setting", the room thermostat will be reset and restore the device to factory default settings.

» PARAMETER MENU – MODBUS INTERFACE

The configuration menu is activated by simultaneously pressing the buttons "up" (A) and "down" (C) for at least 5 seconds.

The menu is enabled during the first 60 minutes after switching on the supply voltage as long as the device is not actively involved in Modbus communication. As soon as the device receives a valid request addressed to the device from a DDC, access to the menu is blocked. Without valid communication, access is blocked after 60 minutes!

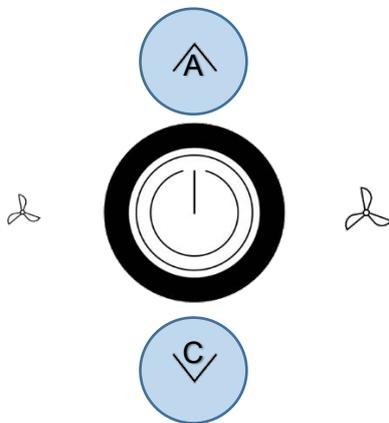

Modbus settings	
Address	◀-/▶ 32
Baudrate	◀-/▶ 19200
Parity	◀-/▶ Even

Address (default: 32)
Adjustable address (1-247)

Baud rate (default: 19200)
9600Bd | 19200Bd | 38400Bd | 57600Bd

Parity (default: even)
Non | odd | even

» **INPUTS**

Up to 2 inputs are configurable for functions such as windows contact, dew point, occupancy, change-over or external sensor option. **The overview of possible combinations can be found in the software specification of the JOY.**

Sensor (NTC10K)	The value of an external sensor will be shown if connected and configured accordingly. In this case, the room thermostat controls according to the external sensor. Alternatively, an external temperature sensor can be used at the universal input to protect floor heating. If a configured temperature is exceeded, the heating sequence is suspended.
Change-Over DI	Which controller is active depends on the state of the Change-Over contact. (Factory default: contact open heating controller active, contact closed cooling controller active). The terminals 4 and 5 are used as outputs for heating resp. cooling.
Change-Over Sensor	The Change-Over Sensor is used for switching between heating and cooling mode automatically. If the temperature is below 22 ° C, the controller is in cooling mode. If it is above 25 ° C, it is a heating mode. If an input is configured as a change-over, the room thermostat is automatically in 2-pipe operating mode and both outputs (terminals 4 and 5) are used as outputs for heating resp. cooling.
Window contact/Energy hold off	If a window contact is enabled via the digital input, the reference will switch to a setback set point (Heat SP/Cool SP).
Dewpoint	An active dewpoint contact locks the cooling controller.
Occupancy	If occupancy-function is active, the symbol will be displayed automatically. In state of "unoccupied" the heating set point is reduced by 2K (default setting) resp. the cooling set point raised by 2K.
Keycard-Switch	When the card is not inserted, the device is switched in sleep mode. Operation of the keys is locked, the display is switched off and the controller adjusts to the nominal values of the "unoccupied"-State.
Alarm contact	An alarm symbol can be shown in the header of the display. The backlight flashes when the alarm is active. This symbol is in the same position as the ECO symbol. The alarm symbol has a higher priority and overwrites the ECO symbol!

» **DIMENSIONS (MM)**

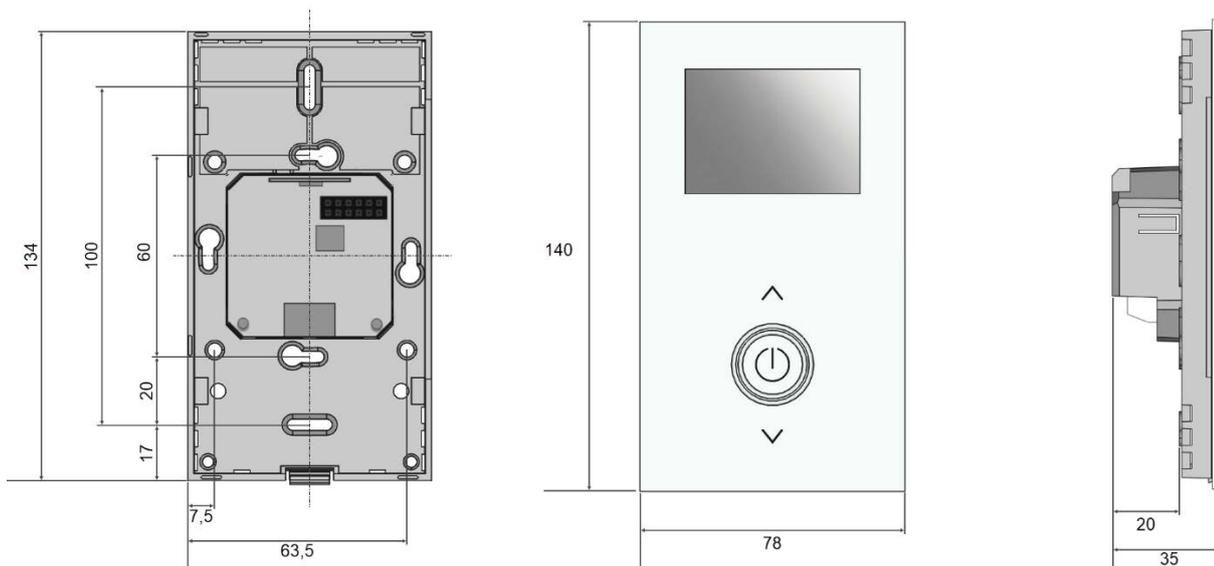

» **ACCESSORIES (OPTIONAL)**

Frame for surface mounting JOY pure white	Item No. 760201
Frame for surface mounting JOY black	Item No. 760951
Decorative frame pure white for JOY	Item No. 681452
Decorative frame black for JOY	Item No. 740951
MicroSD card 2GB	Item No. 500098
RS485 Biasing Adapter	Item No. 811378
USB RS485 Modbus RTU Logger	Item No. 809917
Converter RS485 Modbus - USB	Item No. 668293